

# BEAM ANGLE

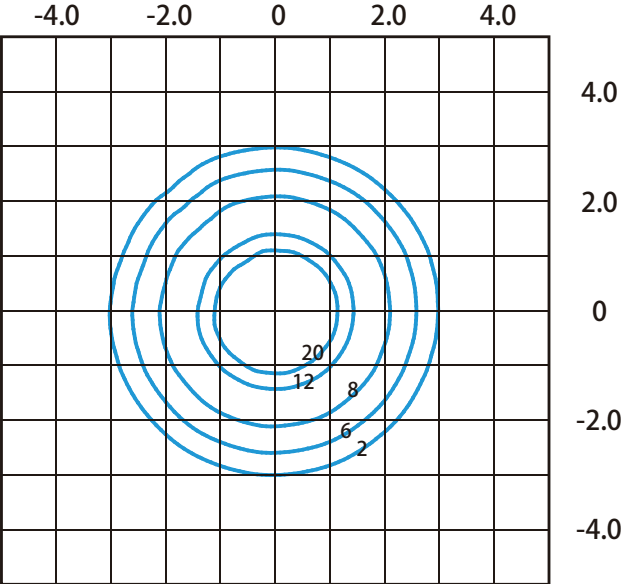
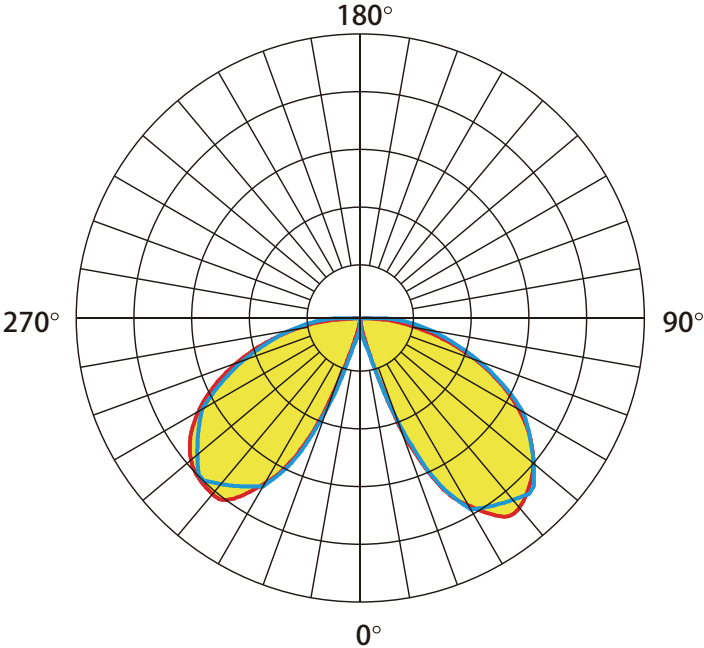

H=1m