

Flush Mount PIR Motion Sensor



HYTRONIK®

HIR27

Independent DALI Occupancy Sensor with Daylight Harvest



CB IP20

Applications

Office, classroom and commercial interior spaces where DALI control is required in small groups.

- Office / Commercial Lighting
- Classrooms
- Stairwells / Corridors

HIR27 with DALI Broadcast Output

Designed with a low profile for aesthetically demanding architectural projects whilst retaining the functionality expected of the latest lighting controls. Control to the light fixtures is provided via self-powered DALI communication (up to 40 drivers).

Set-up of the sensor is carried out using a remote control handset with program memory allowing one-key commissioning where common settings are used for multiple devices.



Features



DALI dimming control based upon occupancy (also known as corridor function).



Daylight harvest function to regulate light output for maintaining required lux level.



Store settings in the remote for easy commissioning when programming multiple sensors.



Intelligent photocell - lights and sensors only operate when needed, natural light has priority.



Synchronisation terminal for grouping of sensors.



5-year warranty

Technical Data

Input Characteristics

Model No.	HIR27
Operating voltage	220~240VAC 50/60Hz
Stand-by power	<0.5W
Switched power	Max. 40pcs devices, 80mA
Warming-up	Appr. 20s
Safety and EMC	
EMC standard (EMC)	EN55015, EN61000, EN61547
Safety standard (LVD)	EN60669-1, EN60669-2-1, AS/NES60669-1/-2-1
Certification	CB, CE, EMC, LVD, RCM ROHS compliance

Sensor Data

Model No.	HIR27
Sensor principle	PIR detection
Detection range	(Ø x H) 10m x 3m
Detection angle	360°
Mounting height	5m (maximum)
Environment	
Operation temperature	Ta: -20°C ~ +50°C
IP rating	IP20

Mechanical Structure

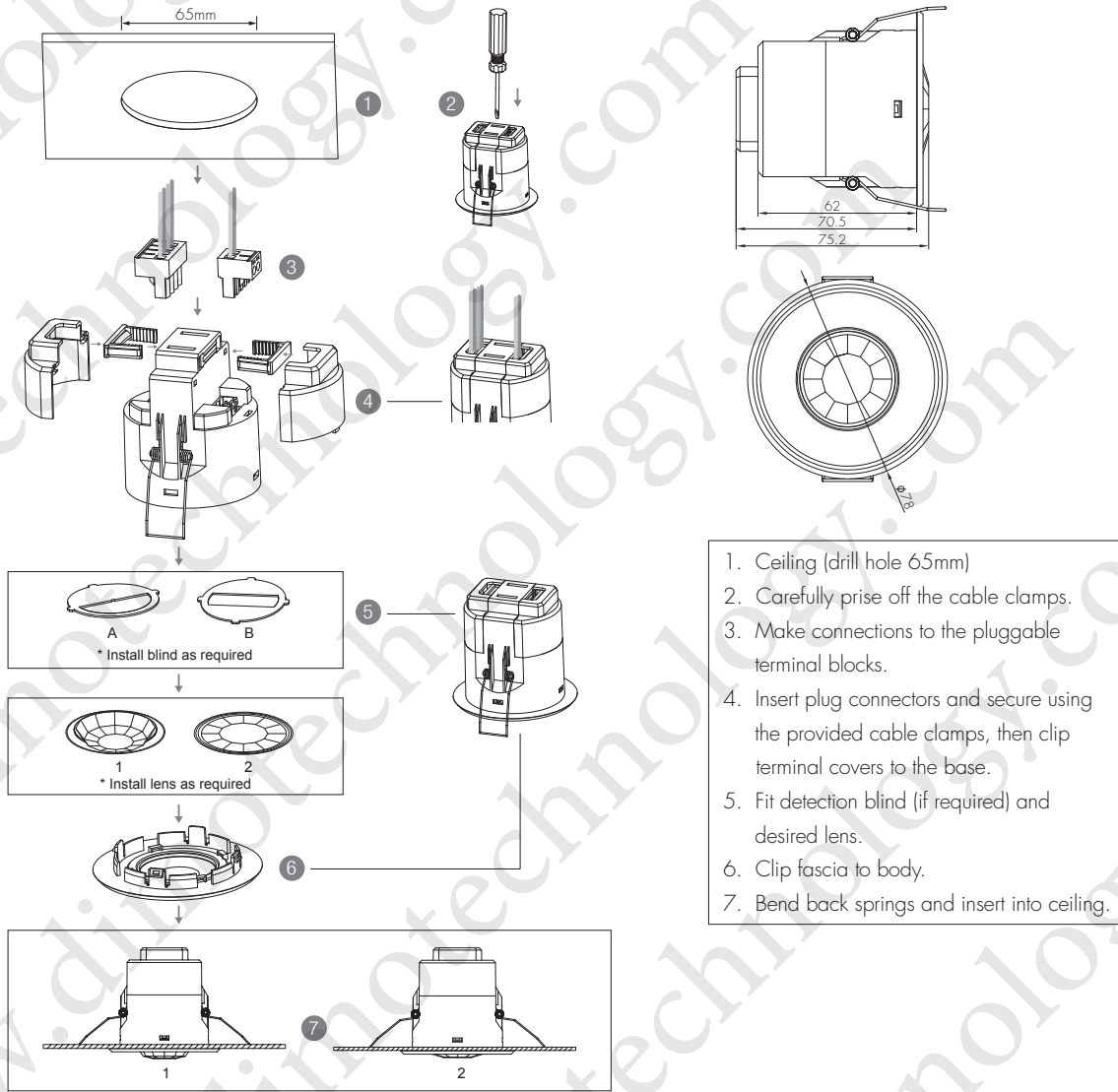

Note: We recommend the mounting distance between sensor to sensor should be more than 2m to prevent sensors from false-triggering.

Optional accessory

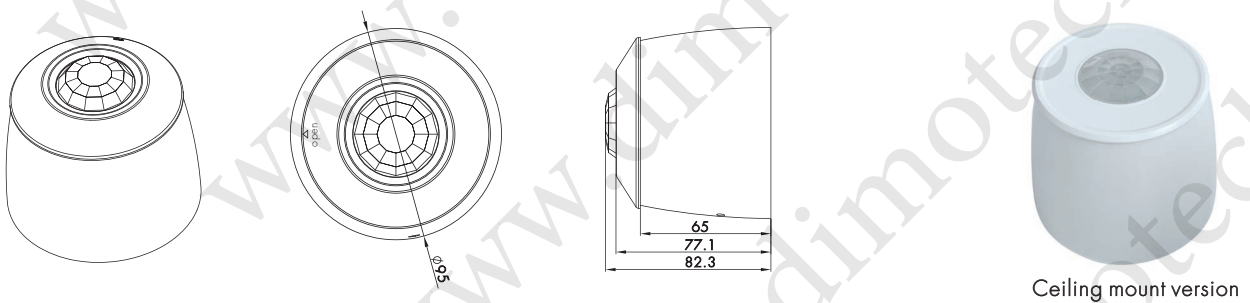

Wiring Diagram

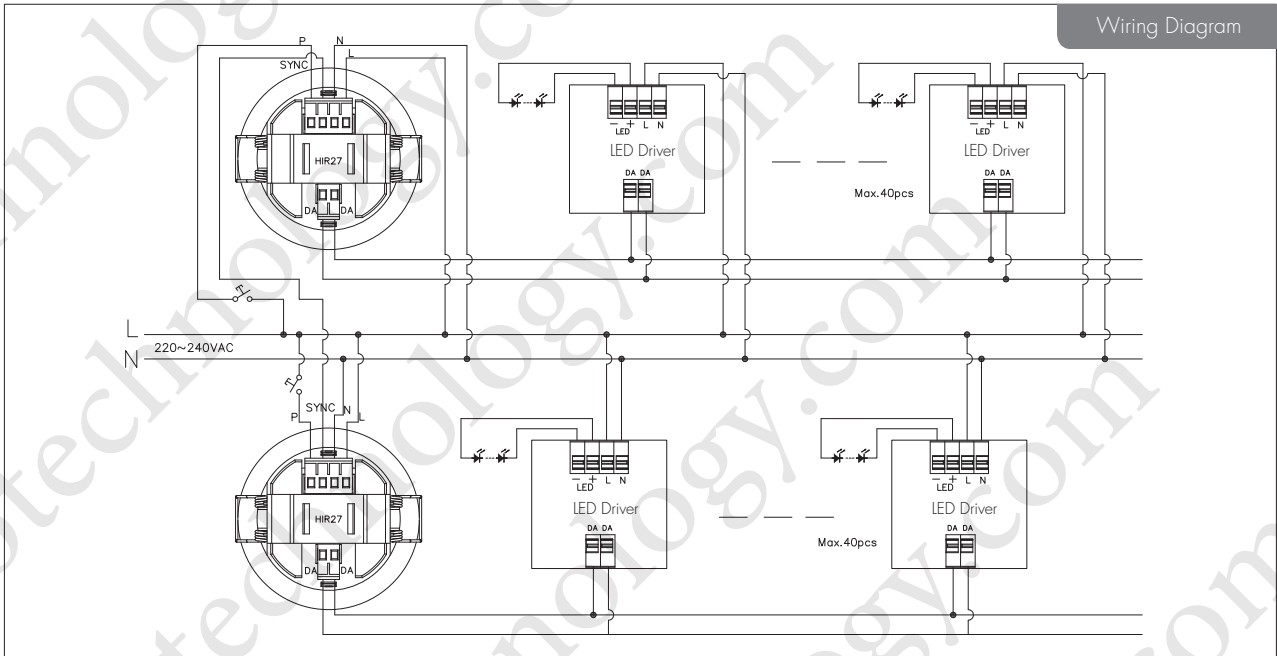

Wire Preparation

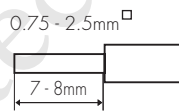

Pluggable screw terminal. It is recommended to make connections to the terminal before fitting to the sensor.

Detection Pattern

Detection range with convex lens

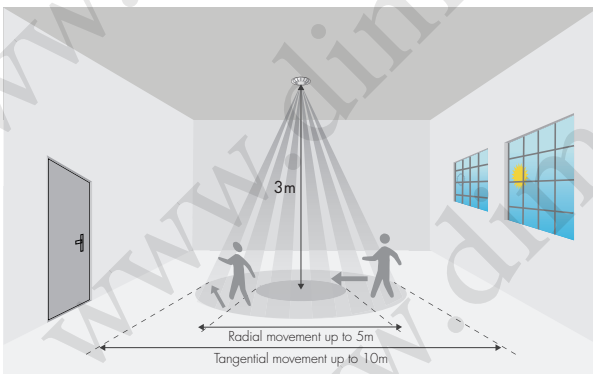

Detection range with flat lens

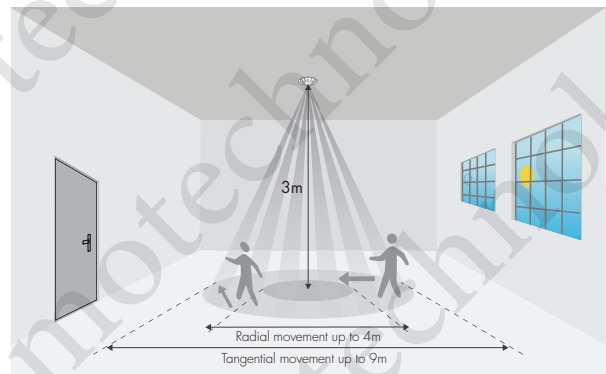
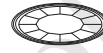

Detection range with convex lens and 50% Blind A

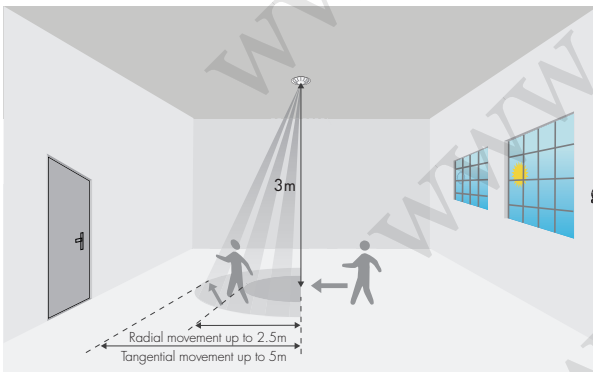

Detection range with flat lens and 50% Blind A

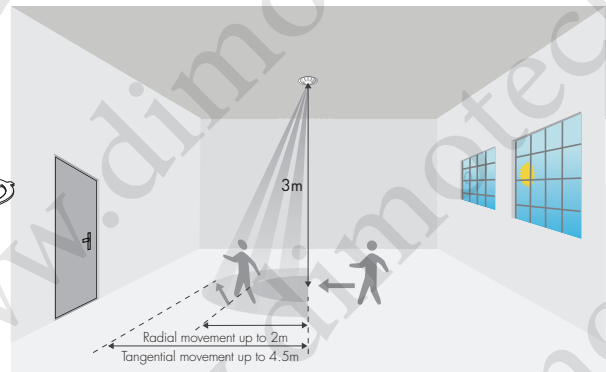

Detection range with convex lens



Detection range with flat lens

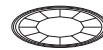

Detection range with convex lens and corridor blind B

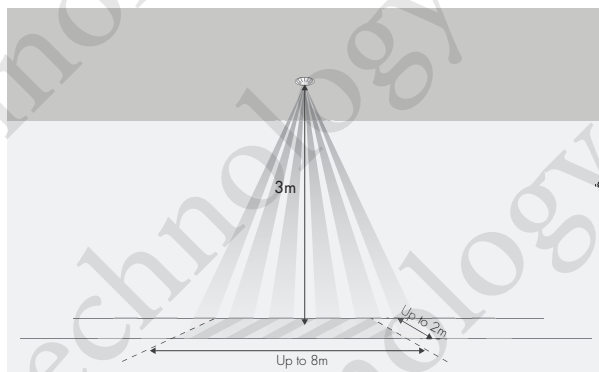

Detection range with flat lens and corridor blind B

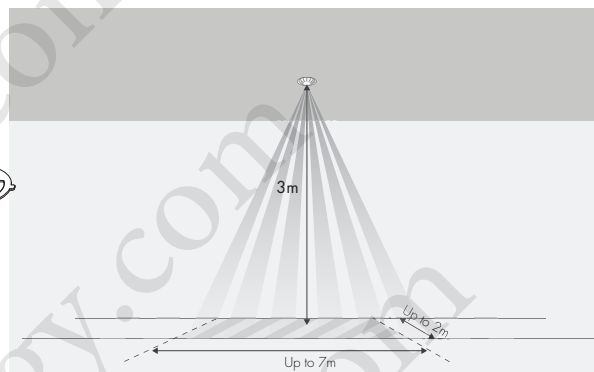

Functions and Features

1 Daylight Harvest

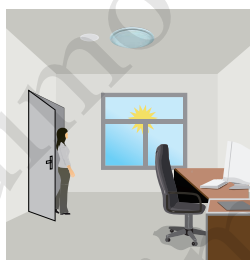

Light will not switch on when natural light is sufficient, even there is motion detected.

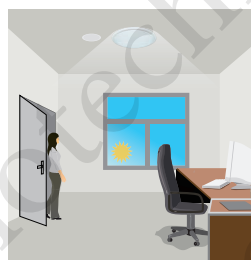

The light switches on automatically with presence when natural light is insufficient.



The light turns on at full or dims to maintain the lux level. The light output regulates according to the level of natural light available.



The light switches off when the ambient natural light is sufficient.

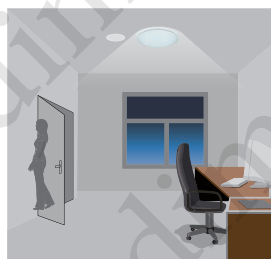

The light dims to stand-by period after hold-time and stays on selected minimum dimming level.

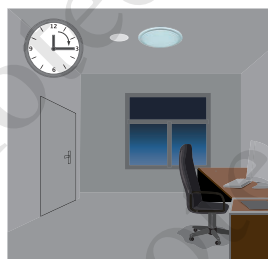

The light switches off completely after the stand-by period.

2 Manual Override

With the help of push-switch, this sensor can be over-riden by the end-user to manually switch on/off the light, or adjust the target lux level by push-switch, which makes the product more user-friendly and offers more options to fit some extra-ordinary demands:

* Short Push (< 1 s): on/off function;

On → Off: the light turns off immediately and cannot be triggered ON by motion until the expiration of pre-set hold-time. After this period, the sensor goes back to normal sensor mode.

Off → On: the light turns on and goes to sensor mode, no matter if ambient Lux level exceeds the daylight threshold or not.

* Long Push (> 1 s): adjust the target lux level by turning the light up or down. Both the adjustment on remote control and push switch can overwrite each other. The last adjustment remains in memory.

Note: if end-user do not want this manual override function, just leave the "push" terminal unconnected to any wire.

3 Semi-auto Mode (Absence Detection)

Selecting this mode will activate the following logic:

Manual on - The lights will not switch on until they have manually been switched on at the wall switch. The occupancy sensor is inactive whilst the lights are off.

Auto off - When the lights are on, the sensor becomes active and monitors the space for activity. Once the area is vacated (absence selection), the sensor will automatically switch off the lights if the last person out forgets to switch off the light manually.

Note: The wall switch can be assigned to function 2 or 3, but not both. The default function is manual override.

4 Synchronisation Function

By connecting the "SYNC" terminals in parallel (see wiring diagram), no matter which sensor detects motion, all HIR27 in the group will turn on the lights when surrounding natural light is below the daylight threshold. The detection area could be widely enlarged in this way.

Settings (Remote Control HRC-11)



Permanent ON/OFF function

Press button "ON/OFF" to select permanent ON or permanent OFF mode.

* Press button "AUTO", "RESET" to quit this mode.



Reset Settings

Press button "RESET", all settings go back to default:

Hold-time 5min, Daylight sensor 100Lux, Stand-by time: 10min, Stand-by dimming level: 20%



Shift Button

Press button "Shift", the LED on the top left corner is on to indicate mode selection.

All values / settings in RED are valid for 20 seconds.



AUTO mode

Press button "AUTO" to initiate automatic mode. The sensor starts working and all settings remain as before the light is switched ON/OFF.

Note: the function of Semi-auto is disabled.



Power output

Press the buttons to select light output at 80% (at initial 10,000 hours) or 100%.

Note: "Sensor off" and "Twilight" functions are disabled.



Brightness +/-

Press these two buttons to adjust the light output brightness and set a new target lux level. The daylight sensor can measure ambient daylight level and ignore the LED light, so as to calculate how much artificial light is needed to maintain the target lux level.

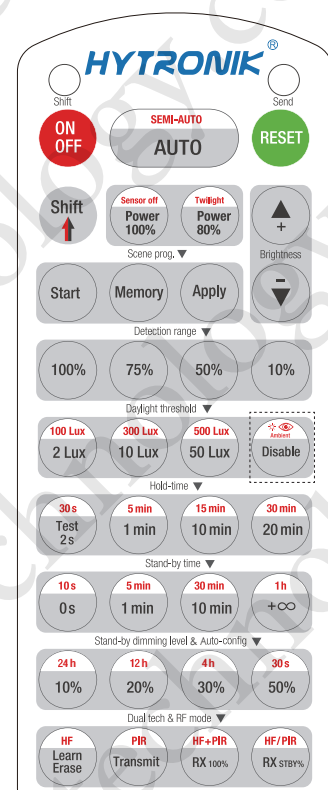

HRC-11



Scene program - 1-key commissioning

1. Press button "Start" to program.
2. Select the buttons in "Detection range", "Daylight threshold", "Hold-time", "Stand-by time", "Stand-by dimming level" to set all parameters.
3. Press button "Memory" to save all the settings programmed in the remote control.
4. Press button "Apply" to set the settings to each sensor unit(s).

For example, to set detection range 100%, daylight threshold Disable, hold-time 5min, stand-by time +∞, stand-by dimming level 30%, the steps should be: Press button "Start", button "100%", "Disable", "Shift", "5min", "Shift", "+∞", "30%", "Memory". By pointing to the sensor unit(s) and pressing "Apply", all settings are passed on the sensor(s).

Detection range

All buttons in this zone are disabled.

Daylight threshold

Press buttons in zone "Daylight threshold" to set daylight sensor at 2Lux / 10Lux / 50Lux / 100Lux / 300Lux / Disable.

Ambient daylight threshold

1. Press button "Shift", the red LED starts to flash.
2. Press button "Ambient", the surrounding lux level is sampled and set as the new daylight threshold.

Hold-time

Press buttons in zone "hold-time" to set the hold-time at 2s / 30s / 1min / 5min / 10min / 15min / 20min / 30min.

Note: 1. To set hold-time at 30s / 5min / 15min / 30min, press "Shift" button first.

2. 2s is for testing purpose only, stand-by period and daylight sensor settings are disabled in this mode.

**To exit from Test mode, press button "RESET" or any button in "Hold-time".*

Stand-by time (corridor function)

Press buttons in zone "stand-by time" to set the stand-by period at 0s / 10s / 1min / 5min / 10min / 30min / 1h / +∞.

Note: "0s" means on/off control; "+∞" means bi-level control, the fixture is 100% on when there is motion detected, and remains at the stand-by dimming level when no presence after motion hold-time.

Stand-by dimming level

Press the button in zone "stand-by dimming level" to set the stand-by dimming level at 10% / 20% / 30% / 50%.

Auto-configuration function

1. Press button "Shift", the red LED starts to flash.
2. Select a time period and the sensor will do light level measurement and determine/save the lowest light level (commission line) with 100% light on, so as to set the target lux level automatically.

Note: 1. Make sure the light level measurement covers the night time.

2. The fixture will go into sensor mode after the measurement, all sensor settings remain unchanged.

Dual tech & RF mode

All buttons are disabled.