

LED EMERGENCY UNDERGROUND LIGHT

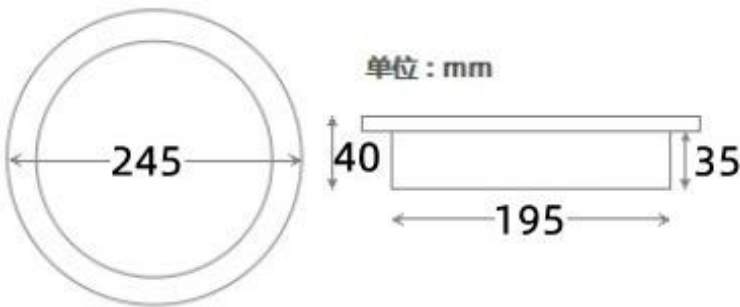

Description:

This product use high quality aluminum shell and tempered glass board as the main material, simple looking design, with durable long life span LED as light source, it can be used in building, hospital, supermarket and other public places



Electrical Specification

- >Input Voltage: AC220/ 50-60Hz
- >Power: 3W
- >Product Size: D245*H40mm
- >Light Source: LED
- >Back Up time: 90/120/180minutes
- >Battery Type: Nickel-cadmium
- >Battery Voltage: 1.2V
- >Material: Aluminum+Tempered Glass
- >Life Span: 50,000 Hours
- >Installation Way: Recessed
- >Net Weight: 0.9kg
- >Gross Weight: 1.2kg
- >IP Grade: IP67

Installation Information:

1. First set up accessories and fittings of the light
2. Cut off the power before installation
3. Make sure the product is fixed tightly to the installation surface
4. Connect the wire of the light to the power supply, then switch on the power

Other Cautions:

1. This product must be installed by professional persons
2. If there is any damage on the power line or the shell of the product, it should be taken as defective product and do not use it
3. Dangerous high voltage, non-professionals are not allowed to maintain the product