

CALON-Ex

IP65 LED Twin Spot Emergency Luminaires

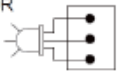

LED INDICATOR



LED Indicate

1. Both fully charged and charging , Both Right and Left green LED Light is ON ,
2. Battery failure: when there is mains power, the Left RED LED light is ON
3. LED Lamp Head Failure. when there is mains power, the green LED light is OFF
4. When discharging, the green LED light is OFF, but the emergency light is working

- Weather Proof IP65 for Outdoor Application bDie-cast aluminium and glass diffuser
- Testing Button integrated for regular maintenance checking
- Adjustable lamp head
- Non- Maintenance Type

Technical Data

Luminaire Type-安裝方式Tipo de luminaria	Surface Mounted or wall Type明裝式或牆裝Montaje en superficie o tipo de pared
Dimension-尺寸-Dimensión	W:270 x H :235 x D:70 mm
Input Voltage-輸入電壓-Voltaje de entrada	AC220-240V 50/60Hz
Emergency Output 緊急輸出 Salida de emergencia	<ul style="list-style-type: none"> • 1W (2x0.5W) LED • 2W (2x1W) LED • 3W (2x1.5W) LED • 4W (2x2W) LED • 5W (2x2.5W) LED
Charge Time 充電時間Tiempo de carga	12hours or 24 Hours
Discharge Duration 放電時間Duración de la descarga	>3 Hours @ Max 5W
System Mode 系統模式 Modo de sistema	Non-Maintained Type 後備 Tipo no mantenido
LED Life-LED壽命-La vida del LED	> 50,000 hrs
Color Temperature -色溫 Temperatura del color	6500K
Color Rendering Index-顯色指數 Índice de reproducción cromática	>80
Beam Angle/光束角/ángulo de haz	• Wide Beam Anlge 90°
Battery Type 電池類型 Tipo de batería	3.2V 6000mAh LiFePO4 磷酸鐵鋰電池
Housing materials-外殼材料 Materiales de la carcasa	Die-cast aluminium and glass 壓鑄鋁和玻璃 Aluminio fundido a presión y vidrio
Housing Color 外殼顏色 color de la carcasa	Grey Color 灰色 Color gris
Ingress Protection-防護等級 Protección de ingreso	IP65
Operating Temperature Range / 工作溫度範圍 Rango de temperatura de funcionamiento	-30 °C / +40 °C
Comply Testing Standard 符合測試標準 Cumplir el estándar de prueba	<p>IEC 60598-1:2020 & BSEN 60598-2-22:2014+A1:2020 at temperature of 850°C and IEC 60695-2-10:2013</p> <p>BS EN 50200: 2015 (PH60) and Annex E of BS EN 50200: 2015 (a duration of survival time of 30 minutes) and one of the following standards:</p> <p>(i) BS EN 60702-1: 2002 +A1: 2015 & BS EN 60702-2: 2002 +A1: 2015</p> <p>(ii) BS 7629-1: 2015 (Cat. Standard 60)</p> <p>(iii) BS 7846: 2015 (Cat. F2 for cables of overall diameter not exceeding 20mm)</p> <p>(b) BS 6387: 2013 Cat. CWZ.</p> <p>The test results from our measurement complied with the relevant sections of BS 5266-1:2016, BS EN 1838:2013 and relevant parts of BS EN 60598-2-22:2014+A1:2020 and regulation PPA / 104 (A) (5th Revision) of Fire Services Department specifications.</p>

Certification-認證-Certificación



Project	Fixture#	Date
		Firm

Ordering Information

Choose the option that suits your need and write its corresponding code on the appropriate line to form the product code.

Example product code: [CALON-EX](#)

CALON-EX - - _____
CALON

CALON	
Code	Description
1W	1W (2x0.5W) LED
2W	2W (2x1W) LED
3W	3W (2x1.5W) LED
4w	4W (2x2W) LED
5W	5W (2x2.5W) LED



BEAM ANGLE

90°

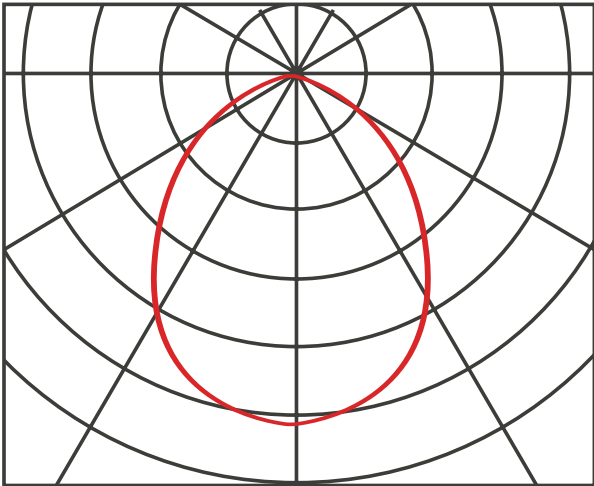

Technical Drawing

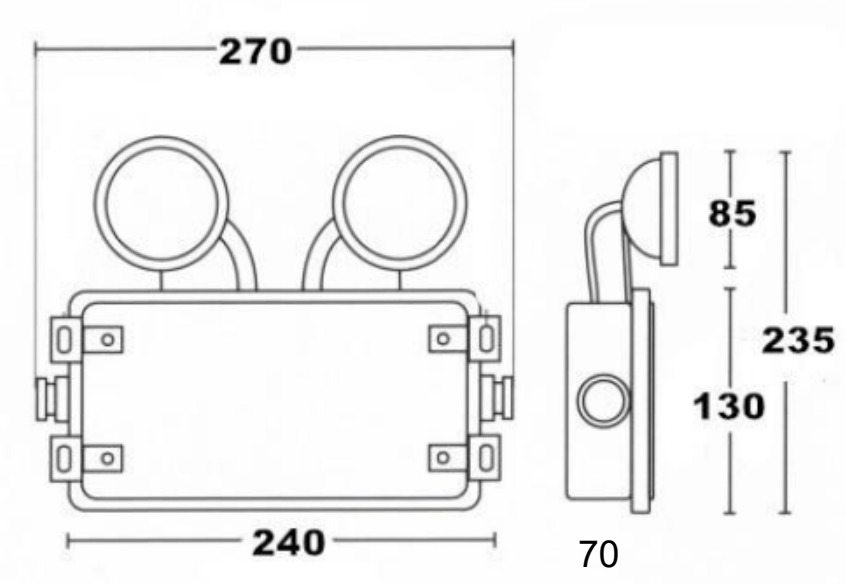

Unit: mm