

## DETON

D100xH105mm 12W Max IP44

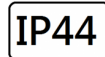

Matt White

Matt Black

Housing: die-cast aluminium, powder-coated, designed as heat sink. Anti-glare reflector and diffusor system made of PMMA. LED module: high-power CREE LEDs Array, CRI>90, LM-80 performance approval >50,000 hours. Integrated-Type ELV , 0-10V, DALI, DMX and RDM LED constant current control gear.

## Technical Data

Luminaire Type-安裝方式Tipo de luminaria	Surface Mounted Type明裝式燈具Superficie Tipo Montado
Dimension-尺寸-Dimensión	Dia 100 x H: 105 mm
QTY of LEDs-燈珠數量-CANT de LEDs	1 pcs CREE LED Array
Power Consumption Max-燈具功率 Consumo de energía Max	• 9W • 12W
Input Voltage-輸入電壓-Voltaje de entrada	AC220-240V 50/60HZ
LED Driver Type LED驅動款式 Tipo de controlador LED	Integrated-type LED Driver--Refer to LED driver specification 請參閱LED驅動器規格 Consulte la especificación de controlador de LED 1. ON/OFF Switch AC220-240V 50/60HZ 2. ELV Dimming Driver (5-100%) AC 100-120V 50/60Hz or AC 200-240V 50/60HZ 3. 0-10V Dimming Driver AC100-240V 50/60HZ 4. Dali Dimming Driver AC100-240V 50/60HZ 5. DMX Driver AC100-240V 50/60HZ 6. RDM Driver AC100-240V 50/60HZ 7. Emergency Backup >2 hours or >3 hours @ < 24 charger hours應急電池/Copia de seguridad de emergencia
LED Driver Features 驅動特性 Funciones del controlador de LED	POWER FACTOR : PF>0.90 @ Full Load TOTAL HARMONIC DISTORTION: THD< 20% EFFICIENCY (Typ.): >85% MAX. No. of PSUs on 16A CIRCUIT BREAKER: 25 units (circuit breaker of type B) / 40 units (circuit breaker of type C at 230VAC)
Control Protocol-控制協議 Protocolo de Control	0-10V / Dali / DMX 512 / RDM / ZIGBEE Wireless Control
Beam Angle光束角ángulo de haz	• 15° 24° 33° 60°
Light Source Brand-光源品牌-Fuente de luz de marca	CREE ( Photobiological safety-IEC 62471 'Risk Group 1' (low risk) )
"Lumen Maintenance LM-80 Reported by TM-21"	1. L90(10k) = 50,700 hrs 2. L80(10k) > 63,500 hrs 3. L70(10k) > 63,500 hrs
LED Life-LED壽命-La vida del LED	>60,000 hours
Color Temperature -色溫 Temperatura del color	2700K / 3000K / 4000K / 5000K / 6500K
Color Rendering Index-顯色指數 Índice de reproducción cromática	• > 80 • > 90
MacAdam Ellipses Binning 麥克亞當橢圓分級 Mac Adam binning ellipse	Standard Deviation Colour Matching < 3 SDCM 標準偏差配色< 3 SDCM Coincidencia de color estándar Desviación < 3 SDCM
Luminaire Efficacy 燈具效率 La eficacia de la luminaria	• 85 Lm/w(2700K), 85 Lm/w(3000K), 90 Lm/w((4000K), • 100 Lm/w(5000K), 100 Lm/w((6500K),
LED Source Luminous Efficacy LED光源光效 Fuente luminosa LED Eficacia	• 125 Lm/w(2700K), 125 Lm/w((3000K), 130 Lm/w((4000K), • 140 Lm/w(5000K), 140 Lm/w((6500K),
Housing materials-外殼材料 Materiales de la carcasa	Die-cast aluminum and acrylic 壓鑄鋁和亞克力 Fundición de aluminio y acrílico
Housing Color 外殼顏色 color de la carcasa	Powder Coating :Matte white body and Matte Black body 粉末塗料: 啞光白和啞光黑 Recubrimiento en polvo: cuerpo blanco mate y cuerpo negro mate
Ingress Protection-防護等級 Protección de ingreso	IP44 - (IEC 60529)
Environment-使用環境-medio ambiente	Indoor
Operating Humidity -工作濕度 Humedad de funcionamiento	0~90%, non-condensing-不結霜 sin condensación
Operating Temperature Range / 工作溫度範圍 Rango de temperatura de función amiento	-30 °C / +50 °C
Comply Testing Standard 符合測試標準 Cumplir el estándar de prueba	LED Luminaires: IEC 60598-1 / IEC 60598-2-1/ Photometric data-IES format LED Driver: EN 55015 / IEC 61000-3-2 /IEC 61347-1 /IEC 61347-2-13/IEC 61547

Certification-認證-Certificación



Project	Fixture#	Date
		Firm



## Ordering Information

Choose the option that suits your need and write its corresponding code on the appropriate line to form the product code.

Example product code: [DETON-9W](#)

DETON - - \_\_\_\_\_  
Power Consumption

Power Consumption	
Code	Description
<a href="#">9W</a>	9W
<a href="#">12W</a>	12W

BEAM ANGLE

15°

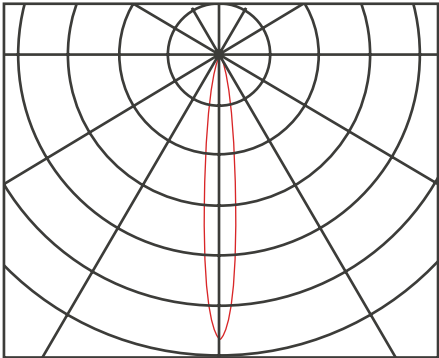

24°

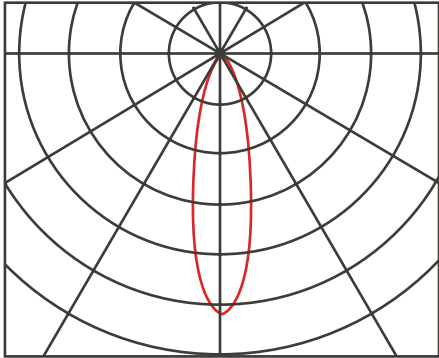

33°

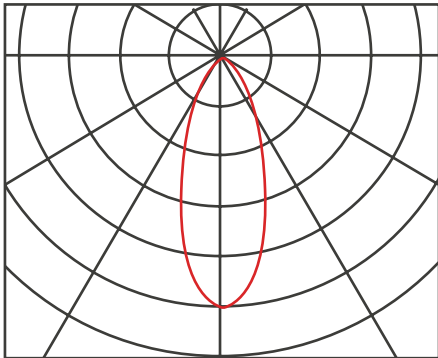

60°

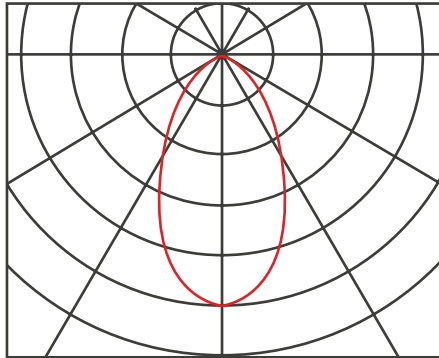

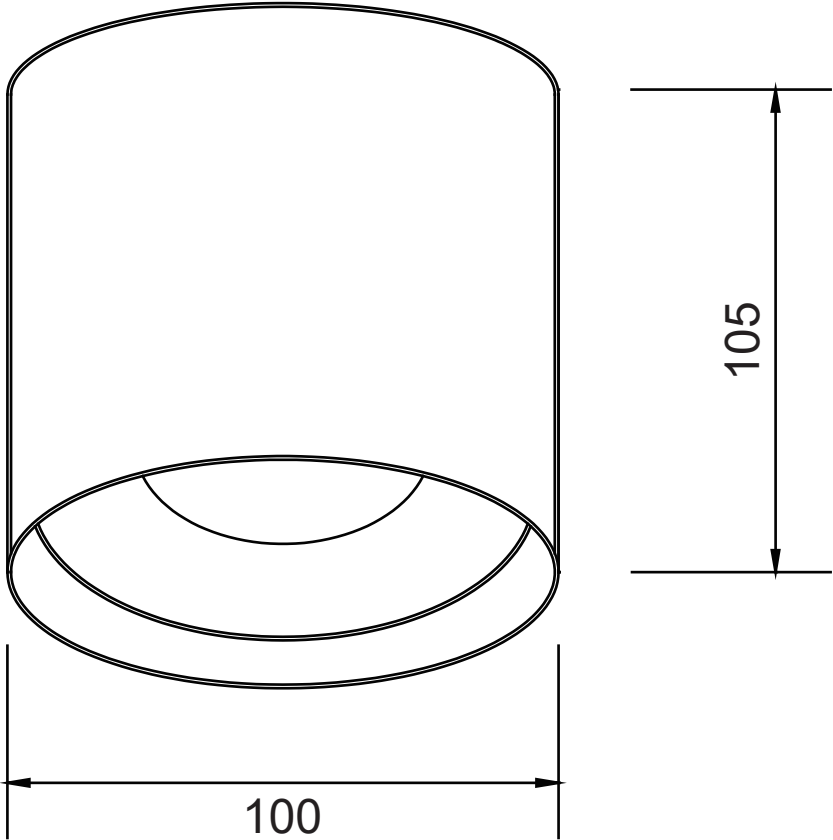

Unit: mm