





## PELO

50W Max 12 Working Hours



- Rechargeable Portable LED Flood Light
- Working Hours : 12 Hours Max
- Die-cast aluminium separate electric housing with super clear tempered glass diffuser and anodised steel bracket
- Extruded Silicone rubber gasket for Ingress Protection to IP65
- Aluminium reflector to distribute symmetric beam angle.
- Built-in Rocker Switch for ON/OFF and Adjustable dimming Switch

## Technical Data

Luminaire Type- 安裝方式 Tipo de luminaria	Surface Mounted and Adjustable Type 明裝可調安裝腳 Tipo montado en superficie y ajustable
Power Consumption with LED Driver LED燈具包括LED驅動電源功率 Consumo de energía con controlador de LED	50W
Input Voltage / 輸入電壓 Voltaje de entrada	• 100-240VAC/50-60HZ by using Charging Adapter • Charging Adapter (Output DC24V)
Power Factor / 功率因數/Factor de potencia	PF>0.90
Lumen Maintenance LM-80 Reported by TM-21	> 59,000 Hours @ L70
Light Source Brand-光源品牌-Fuente de luz de marca	DeRunda LED Array with LM-80-08 Certificate
Color Temperature and Color 色溫和顏色 Temperatura y color del color	• 3000K • 4000K • 5000K • 6000K
Color Rendering Index-顯色指數 Índice de reproducción cromática	>70
Beam Angle 光束角 ángulo de haz	120°
Luminaire Efficacy 燈具效率 La eficacia de la luminaria	• 4000lm @ 80 Lm/w (3000K) • 4750lm @ 95 Lm/w (4000K) • 5000lm @ 100 Lm/w (5000K) • 5000lm @ 100 Lm/w (6500K)
Battery Type 電池類型 Tipo de Batería	18.5V,6.6Ah Lithium battery / 鋰電池 / Batería de Litio (IEC 62133) Life Cycle: > 400 times
Charging Time / 充電時間 / Tiempo de carga	6 hours / 6個小時 / 6 horas
Working Time 工作時間 Tiempo de trabajo	3 to 12 hours / 3至12個小時 / 3 a 12 horas
Housing materials 外殼材料 Materiales de la carcasa	Die-cast aluminium and Tempered glass and Extruded Silicone rubber gasket and Iron Bracket 壓鑄鋁和鋼化玻璃和擠壓矽橡膠墊圈和鐵支架 Aluminio fundido a presión y vidrio templado y junta de goma de silicona extruida y soporte de hierro
Housing Color 外殼顏色 color de la carcasa	• Black and Yellow • 黑色和黃色 • Negro y amarillo
Ingress Protection-防護等級 Protección de ingreso	IP65 - (EN 60529)
Operating Temperature Range / 工作溫度範圍 Rango de temperatura de funcionamiento	-20 °C / +50 °C
Storage Temperature 儲藏溫度 Temperatura de almacenamiento	-20 °C / +60 °C
Operating Humidity -工作濕度 Humedad de funcionamiento	0~98%, non-condensing-不結霜 sin condensación
Dimension (LxWxH) / 尺寸 / Dimensión	• 360*230*385mm
Net Weight / 淨重/ Peso Neto	• 4.86kg
Packing box size 包裝箱尺寸 Tamaño de la caja de embalaje	400*260*420mm
Country of Origin 產地	PRC 中國
Warranty Period 保修期 Periodo de garantía	2 Years 2年 2 años
Comply Testing Standard 符合測試標準 Cumplir el estándar de prueba	• LED Luminaires LVD : EN 60598-1 / EN 60598-2-8 / EN 62493 / EN 62471 / EN 62031 / EN 60529 UL94 Class V0 (BS476 Part 7 Class 1) • LED Luminaires EMC : EN 61000-3-2 / EN 61000-3-3 / EN 61547 / EN 55015 • Battery Safety Testing : IEC 62133 • ROHS
Certification-認證-Certificación-	    

Project	Fixture#	Date
		Firm



## Ordering Information

Choose the option that suits your need and write its corresponding code on the appropriate line to form the product code.

Example product code:

PELO - - \_\_\_\_\_  
COLOR TEMPERATURE

COLOR TEMPERATURE	
Code	Description
30	3000K
40	4000K
50	5000K
65	6500K

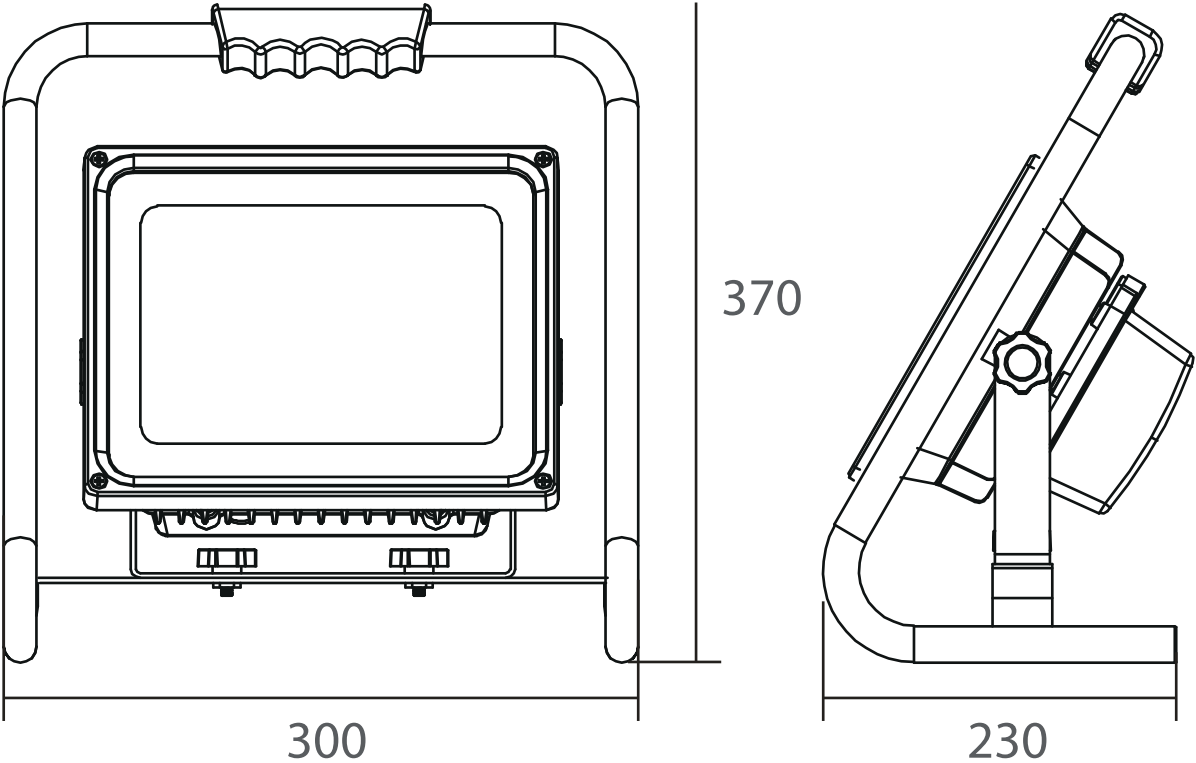

Unit: mm