

E-NANO

30% & 50% Output LED Emergency Power Pack - Inverter for LED Lighting with LED Driver

30 & 50% Output wiring with general lighting switch diagram

30 & 50% 輸出接駁燈制開關接線圖

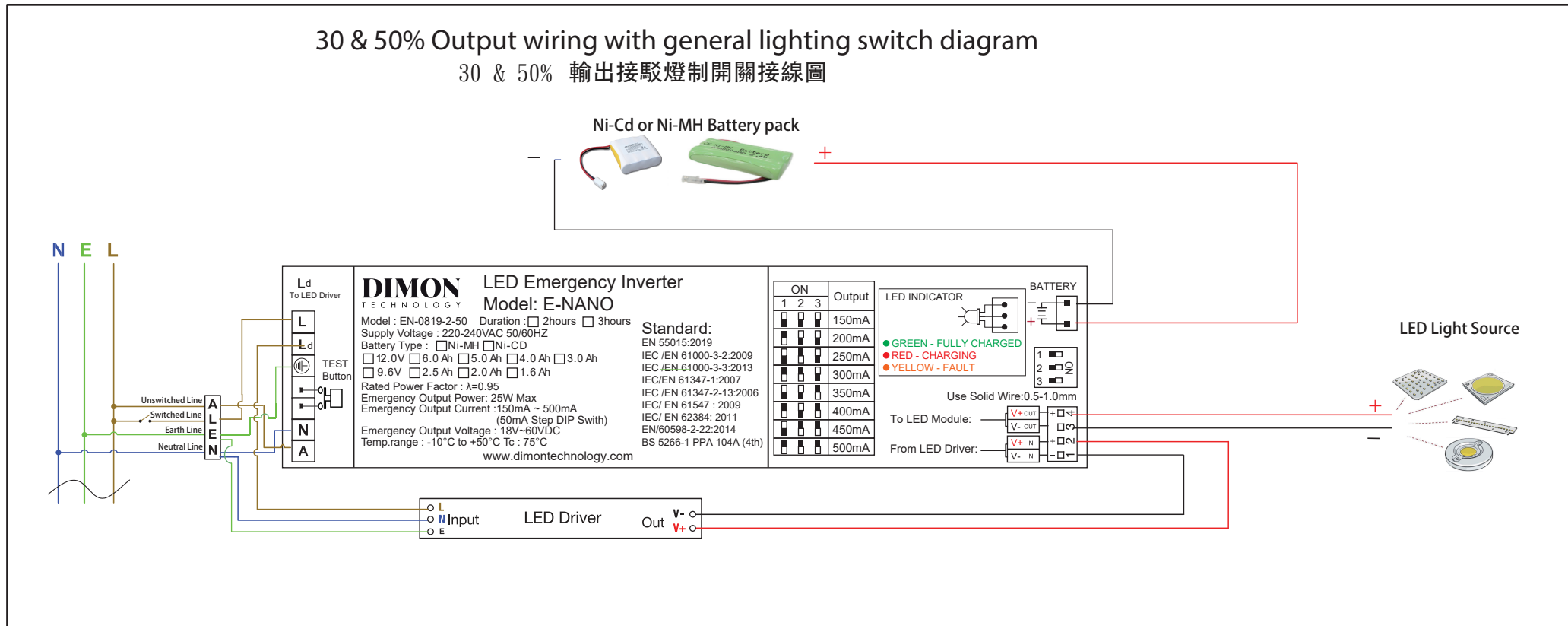

E-NANO

30% & 50% Output LED Emergency Power Pack - Inverter for LED Lighting with LED Driver

30 & 50% Output wiring with general lighting switch and 0-10V, DALI, DMX512 or Zigbee Wireless diagram

30% & 50%輸出接駁燈制開關配合0-10V ,DALI,DMX512 ,或者Zigbee Wireless 調光接線圖

Ni-Cd or Ni-MH Battery pack

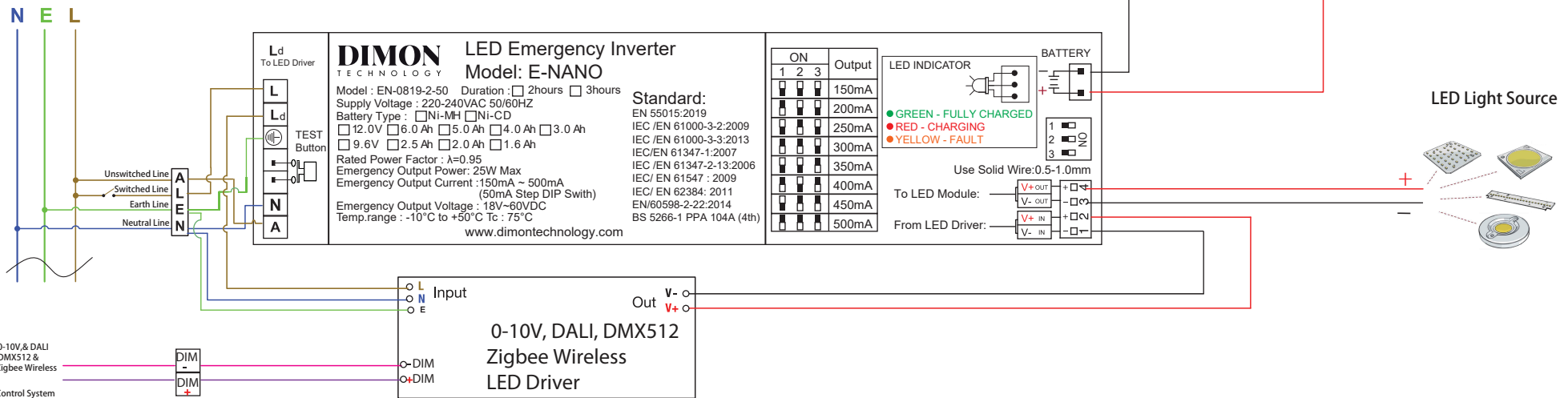

E-NANO

30% & 50% Output LED Emergency Power Pack - Inverter for LED Lighting with LED Driver

30 & 50% Output wiring diagram (Maintained Type)

30% & 50% 輸出接線圖 (長明式)

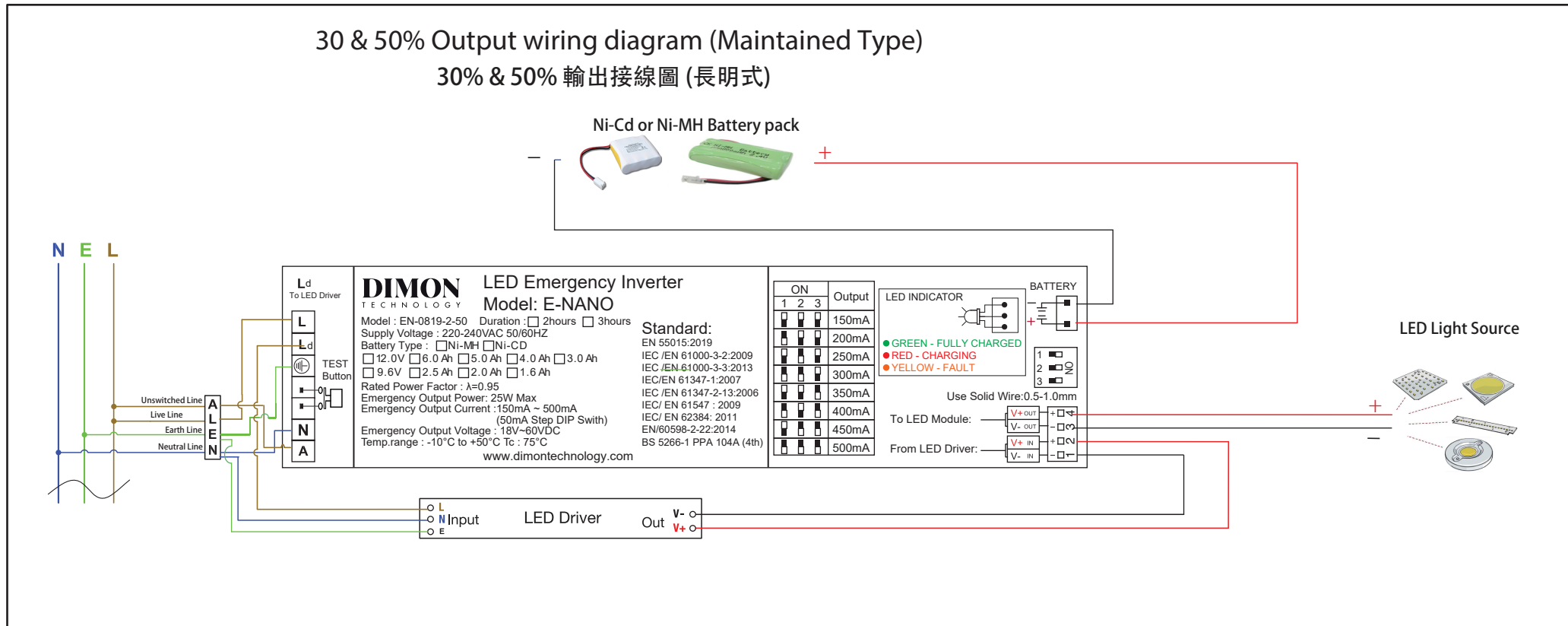

E-NANO

30% & 50% Output LED Emergency Power Pack - Inverter for LED Lighting with LED Driver

30 & 50% Output wiring for 0-10V, DALI, DMX512 or Zigbee Wireless dimming diagram (Maintained Type)

30% & 50%輸出接駁0-10V ,DALI,DMX512 ,或者Zigbee Wireless 調光接線圖(長明式)

Ni-Cd or Ni-MH Battery pack

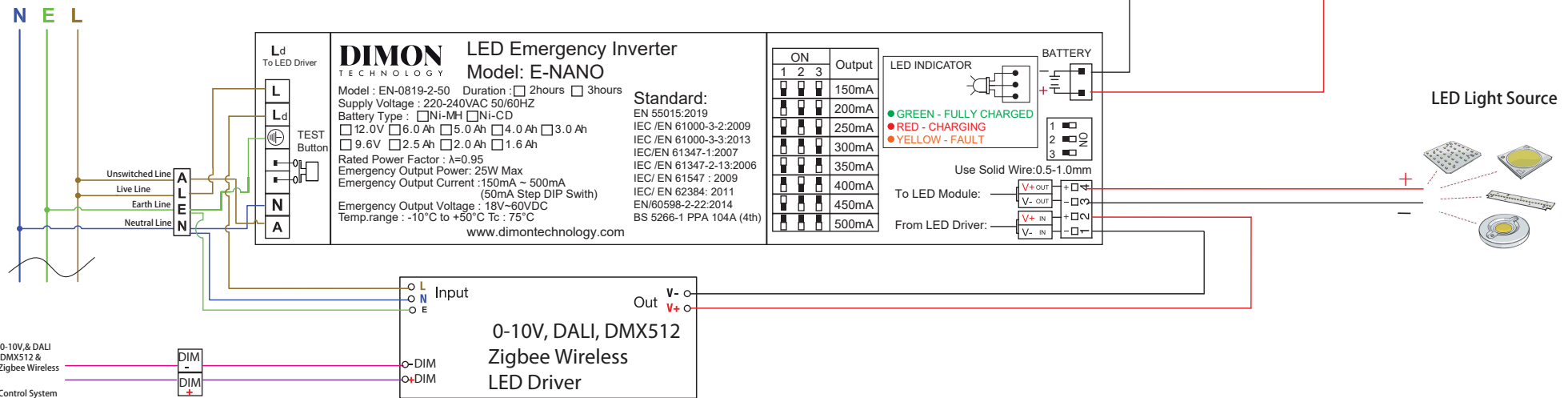
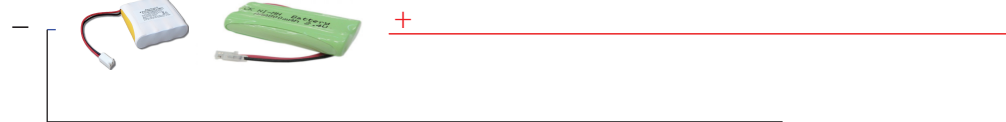

E-NANO

30% & 50% Output LED Emergency Power Pack - Inverter for LED Lighting with LED Driver

30 & 50% Output wiring diagram (Non-Maintained Type)

30% & 50% 輸出接線圖 (後備式)

